



Spectral flux of the p-⁷Li(C) quasi-monoenergetic neutron source measured by proton-recoil telescope

J. Novák, P. Bém, J. Mrázek, Z. Hons, M. Honusek, M. Götz, E. Šimečková
and M. Štefanik

Nuclear Physics Institute ASCR PRI, Řež, Czech Republic

S.P. Simakov, U. Fischer

*Karlsruhe Institute of Technology, Institute of Nuclear Physics and Reactor Technology
Karlsruhe, Germany*



The NPI p-⁷Li neutron source target station

The ⁷Li(p,n) reaction on thin ⁷Li foil target is commonly utilized for activation cross sections measurement at higher (20 MeV) neutron energies

- For the ⁷Li(p,n) source, transmitted protons must be declined by **magnetic field** → irradiated samples are located at large distance from the ⁷Li target → neutron flux at investigated samples is limited.
- In an alternative method, transmitting protons are stopped by **carbon backing**
- The Li(C backing) source is suitable for proton incident energies up to 40 MeV due to 19.6 MeV threshold of ¹²C(p,n) reaction. The contribution of p+C neutrons to the low-energy tail of spectrum is acceptably low.

NPI target (compared to TU set) is settled by cooling system (higher beam power).

- Additional large-dimension hardware could lead to **larger parasitic neutron contribution. Correct determination is required.**

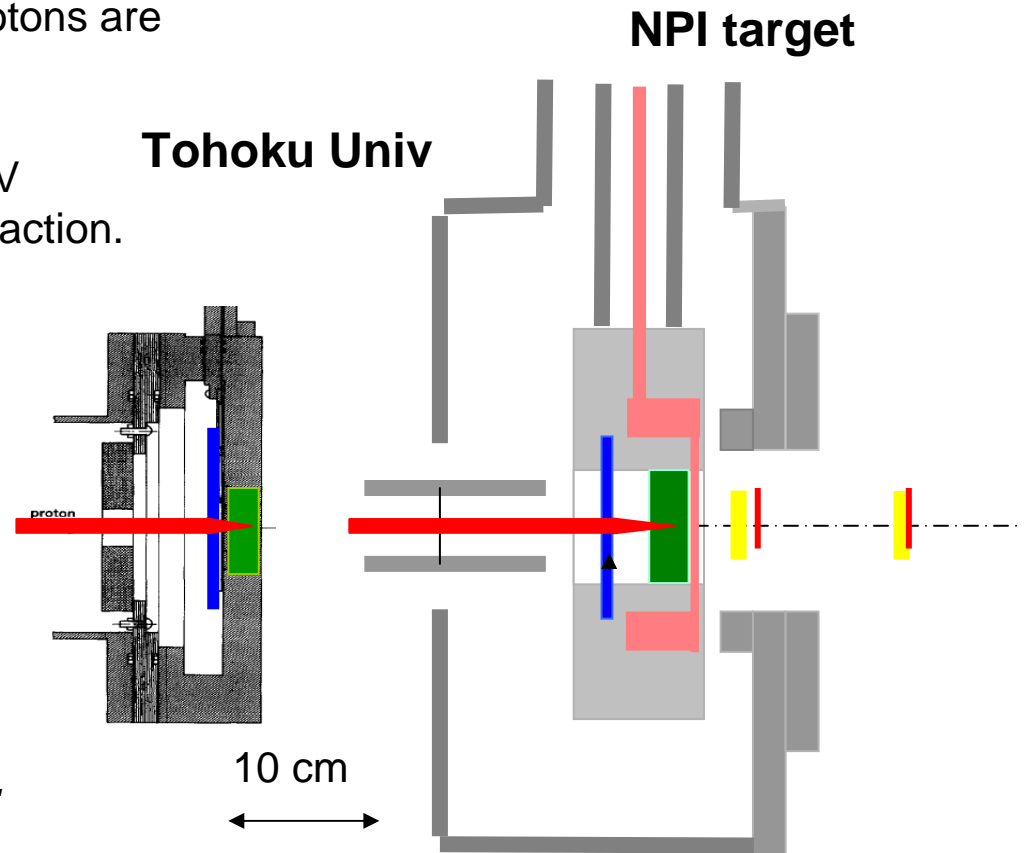



Composition of ${}^7\text{Li}(\text{Cbacking})$ source spectrum

Data from TOHOKU TOF experiment [Y. Uwamino et al., NIM A389(1997)463]

Available in the form of graphs only

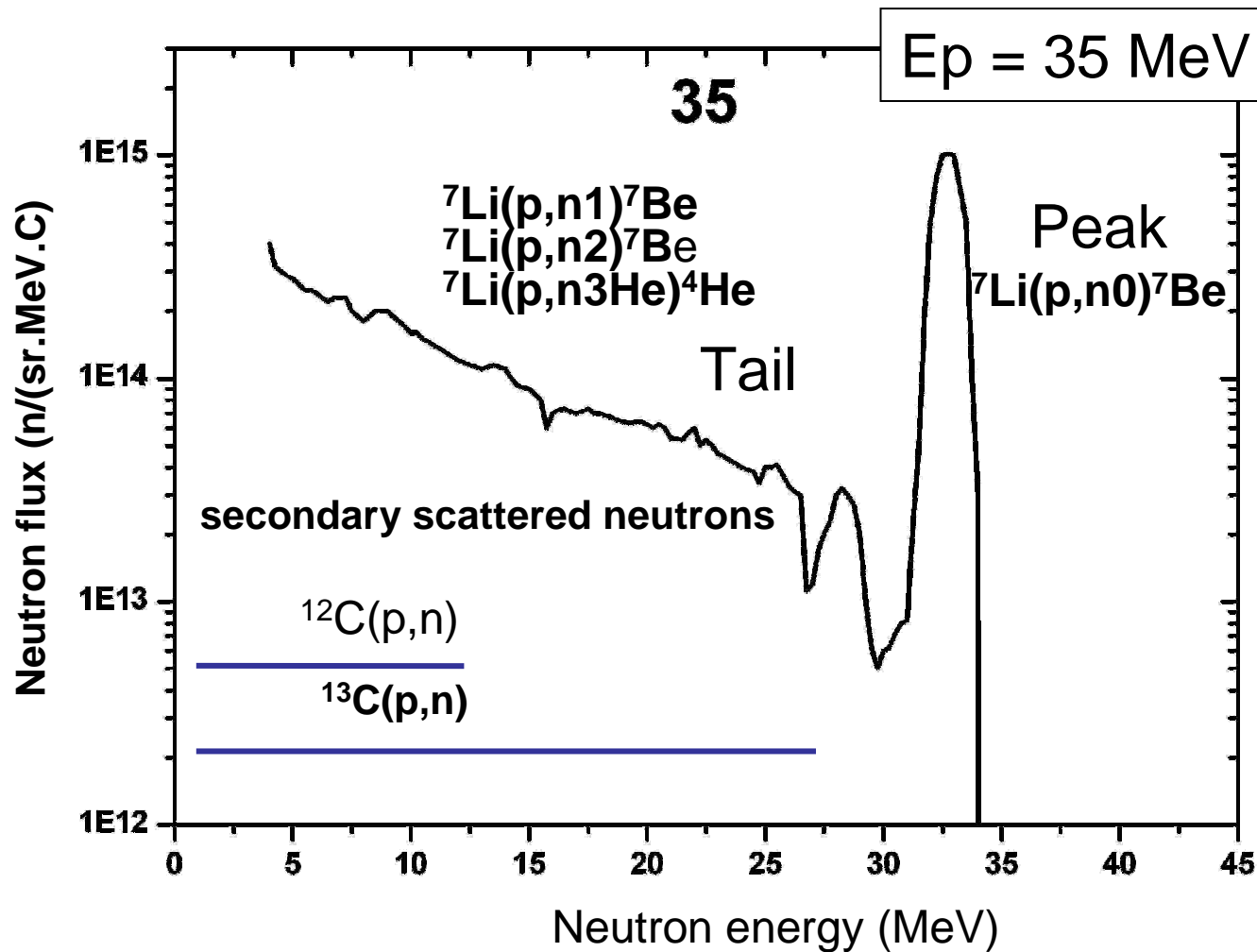



Propagation of the tail to an uncertainty of measured cross section

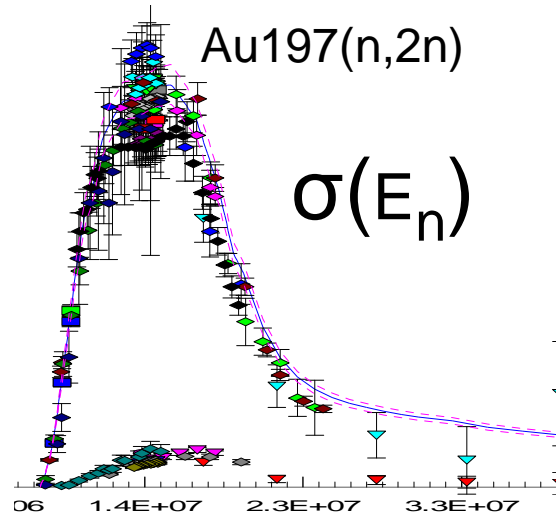

In the investigation of backing part of activation cross section functions the tail part of p-Li spectrum contributes considerably to measured Reaction Rate.

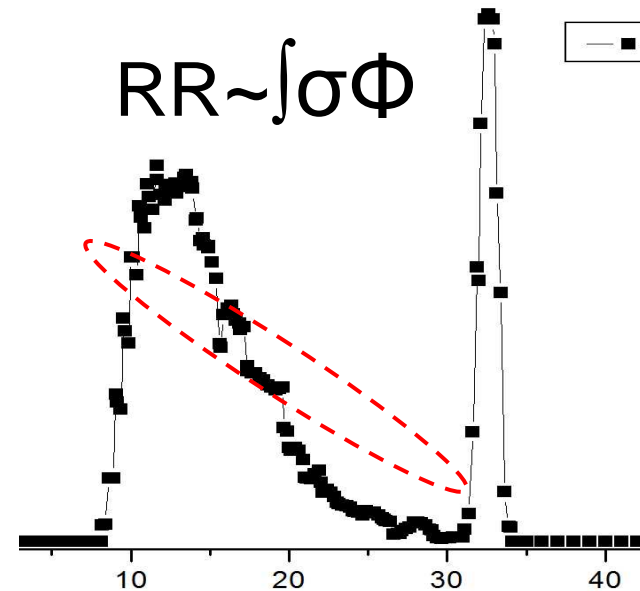
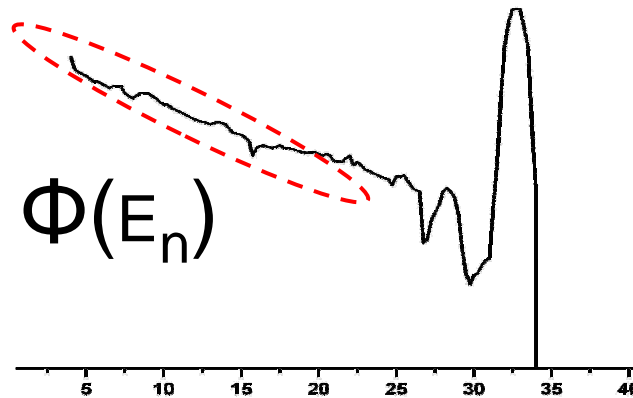



Spectrum at sample position

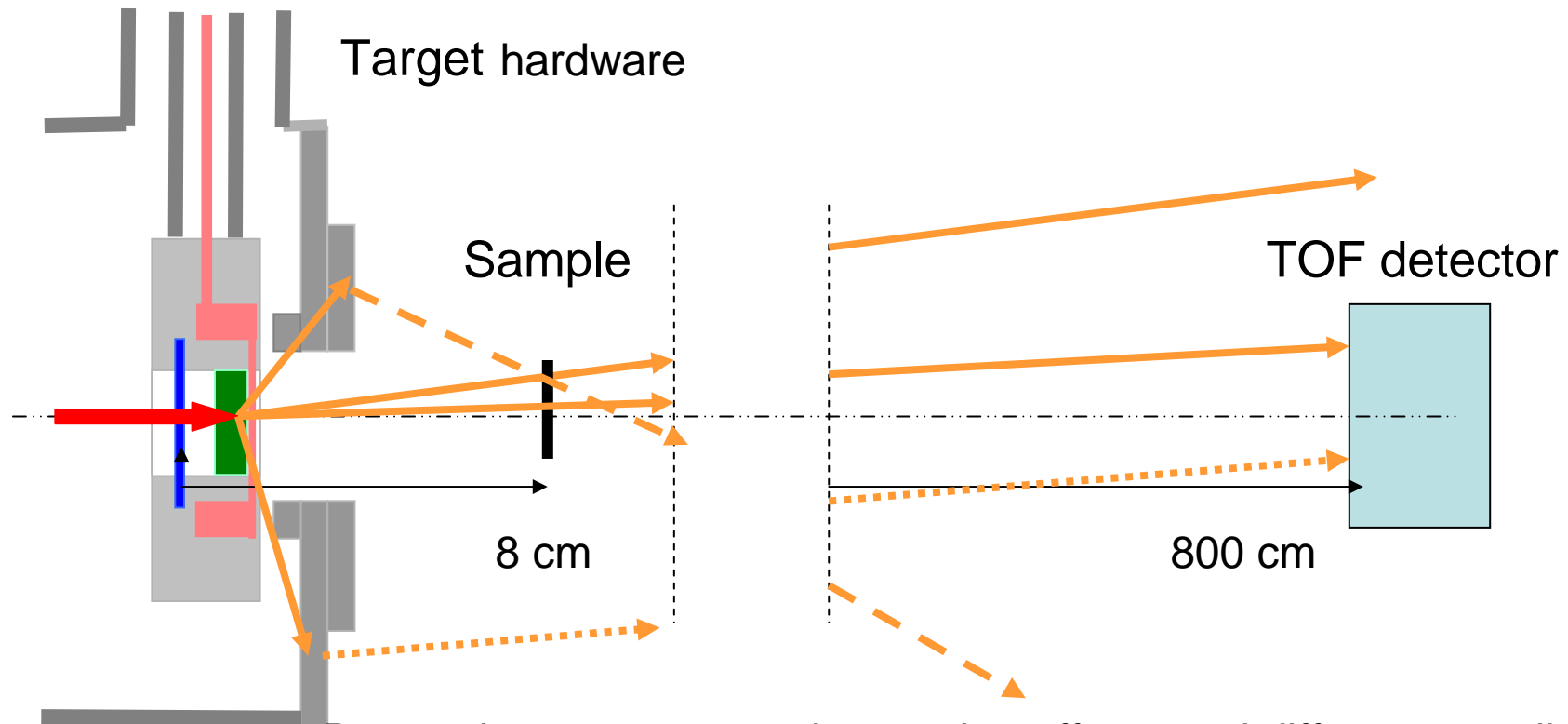

Due to the strong space-integration effects and different contribution of secondary neutrons to the sample and to distant TOF detector

- *the low-energy tail of spectrum at sample location could not be completely determined by TOF measurement*
- *the employment of experimentally tested Monte-Carlo (MCNPX) simulation as only way is strongly required*



Proton Recoil Telescope for Neutron Spectroscopy

- The Proton Recoil Telescope (PRT) is based on the detection of protons in the $n+p$ scattering on a thin hydrogenated target.
- By correcting for the energy dependent efficiency, the energy spectrum for the neutrons emitted by the source is determined from the detected proton spectrum, on the kinematics relations basis.
- Protons are detected at defined angle by telescope of Si detectors.

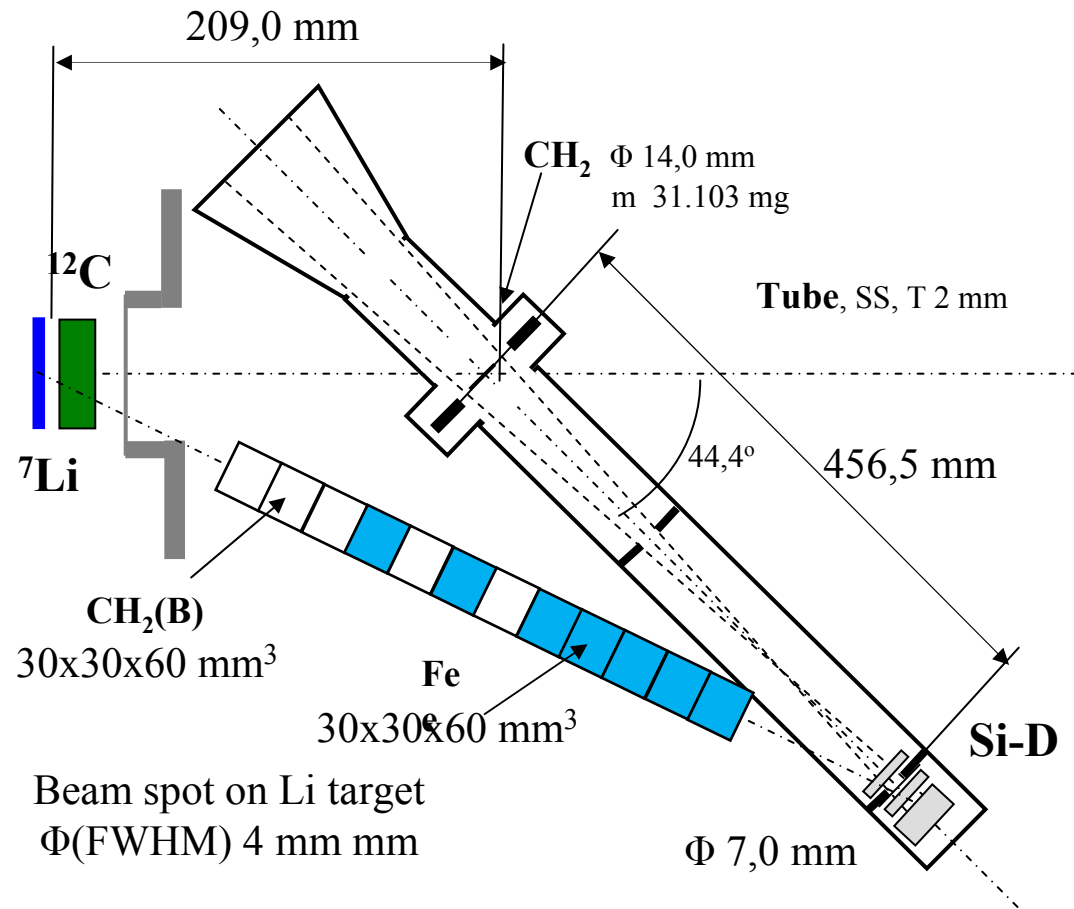

The PRT is proposed to detect neutron spectrum at short distances from the source where TOF method is not applicable



Technical arrangement of PRT experiment

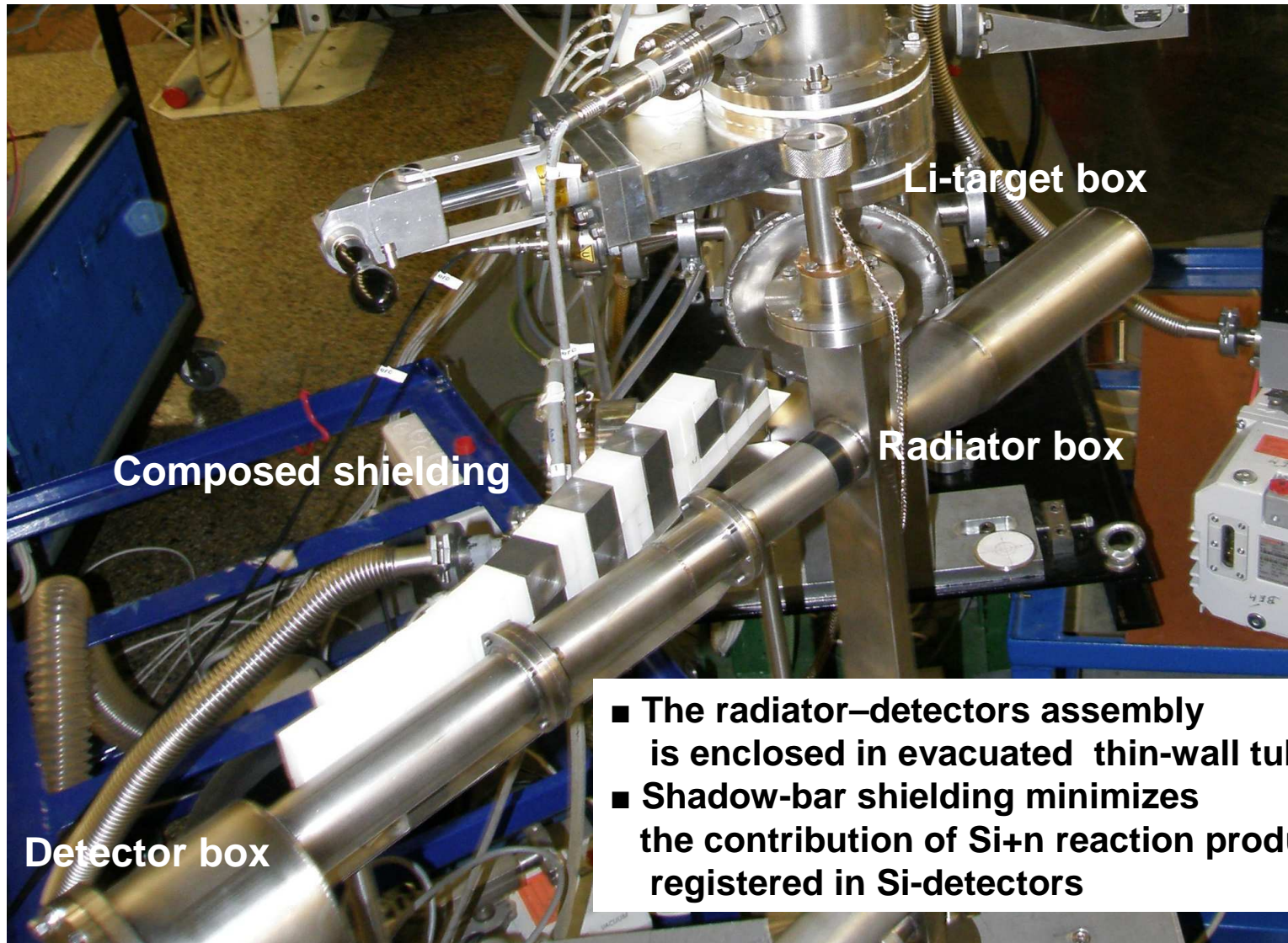

- The radiator–detectors assembly is enclosed in evacuated thin-wall tube
- Shadow-bar shielding minimizes the contribution of $\text{Si}+n$ reaction products registered in Si-detectors



Registration technique

Protons were distinguished from other particles by Bethe formula

$$E \cdot \Delta E \approx A \cdot Z^2$$

Telescope consists from 3 Si detectors:

- $\Delta E1$ thin Si 45 μm
- $\Delta E2$ thin Si 90 μm
- E thick Si 5 mm

- Each of 3 detector signals was
 - 1) amplified in Ortec 142 preamplifier
 - 2) amplified in Ortec 572 amplifier
 - 3) converted in LeCroy 3351 converter
 - 4) saved on PC hard disc with time labels for time coincidence definition
- Quick $\Delta E2$ signal from preamplifier served for converter gate pulses generation
- Pulses from external generator were detected simultaneously with detector events to estimate precisely the dead time effects.

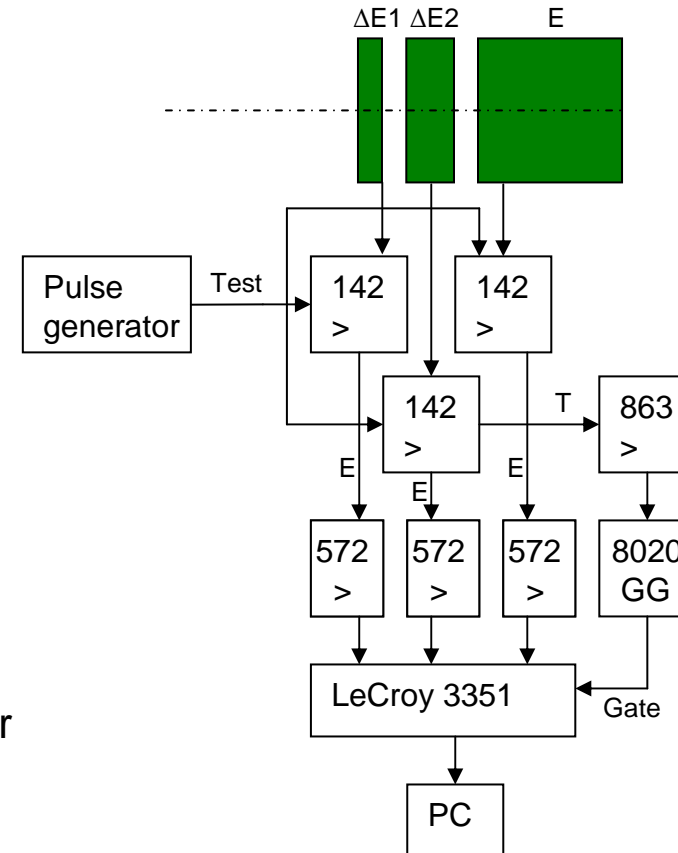



Experimental procedure and data processing

- 27.6 MeV proton beam energy was used. Typical beam current was 4 μA , typical charge 0.3 C
- Three expositions were performed: a) CH_2 (31.103 mg), b) C radiator (38.70 mg), c) radiator-free
- p-beam current is registered, ^7Be activity in Li foil were measured to test the ^7Li foil thickness

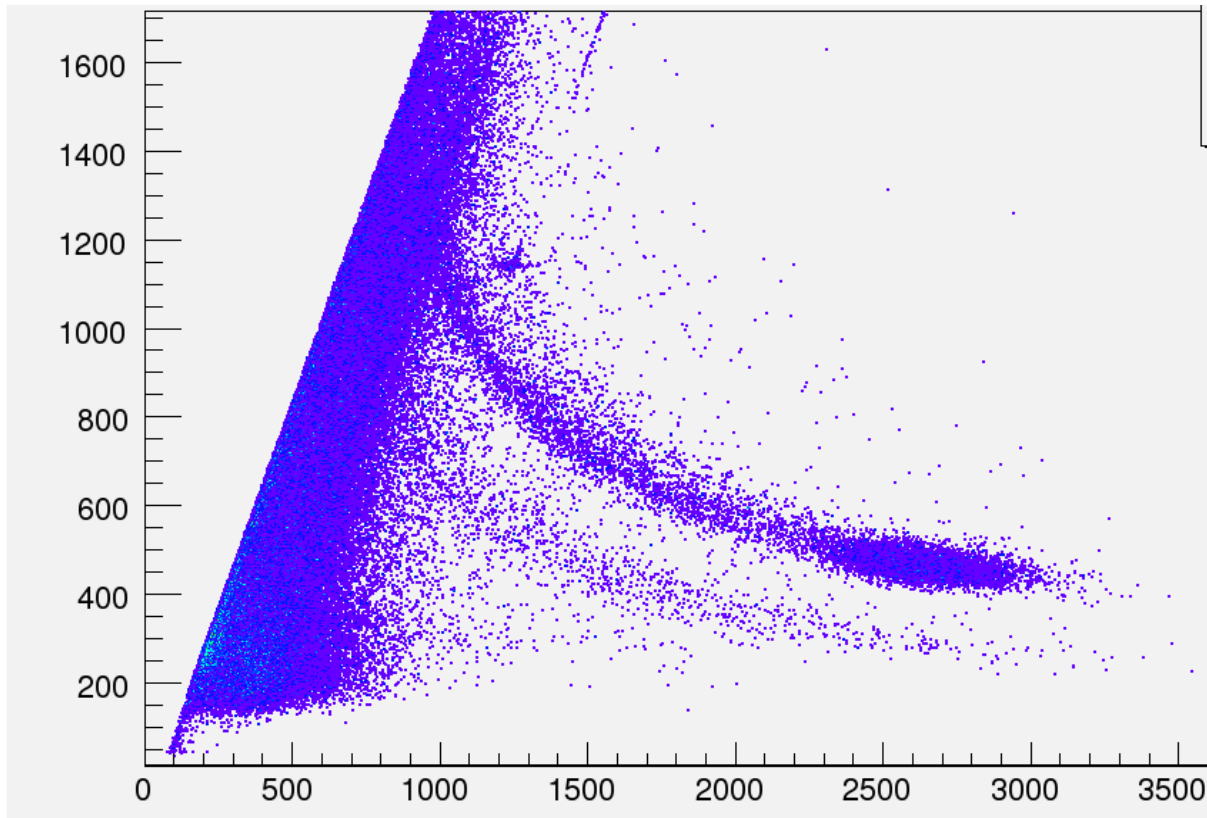

During off-line data processing, 2 dimensional matrices were composed:

$\Delta E1 \times (\Delta E1 + \Delta E2 + E)$ matrix

distinguishes proton with energy from 2,5 MeV, but in case of highest proton energies, the energy losses in $\Delta E1$ may be under detection threshold.

$(\Delta E1 + \Delta E2) \times (\Delta E1 + \Delta E2 + E)$

matrix distinguishes proton with energy from 4,5 MeV, but the proton energy losses are detectable also for highest proton energies.

Normalized single spectra that cover different part of proton spectrum were cumulated.



Resulting proton-recoil spectrum

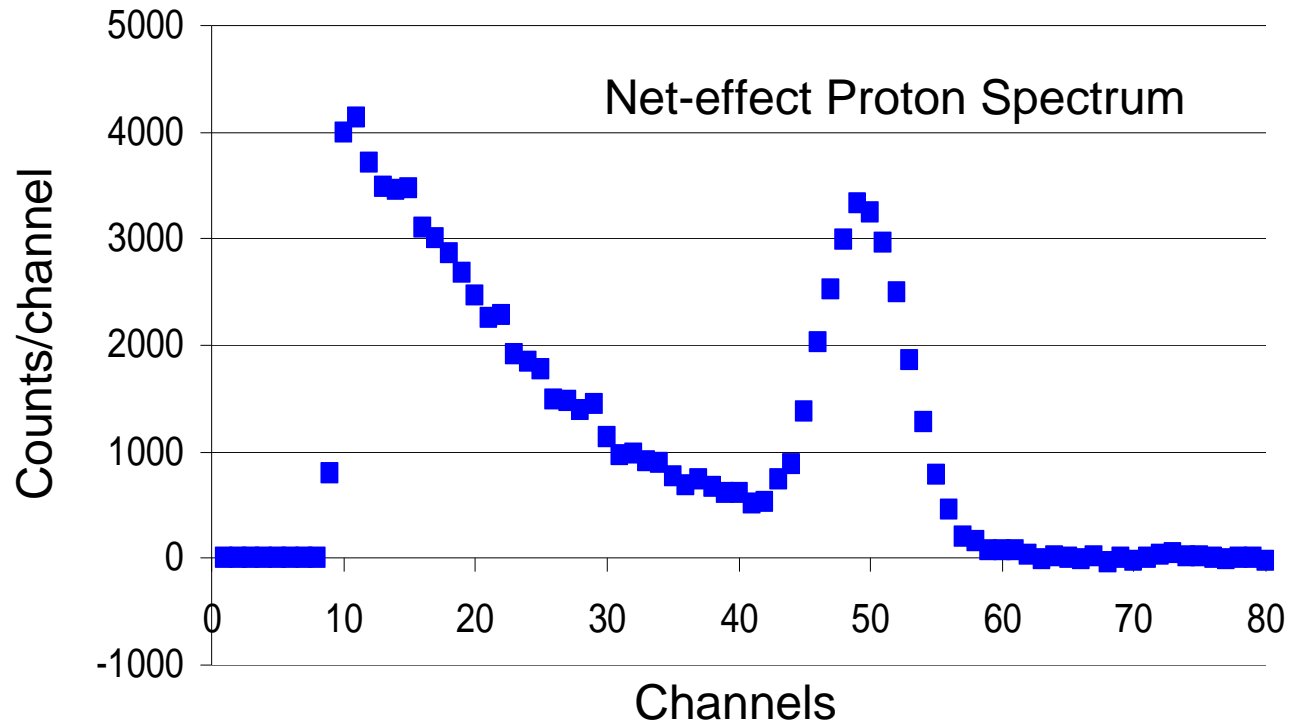

- The normalized exposition without radiator was subtracted from CH_2 and C exposition for obtaining CH_2 and C proton spectra without other proton sources contribution.
- Normalized C proton spectrum was subtracted from that of net CH_2 spectrum
- *Resulting spectrum of n-H recoil process was obtained (net effect) with good statistics.*



Simplified reconstruction of neutron spectrum

- A code for the reconstruction of neutron spectrum from measured proton recoil spectrum was developed. In the code, the response function is based on the n+p differential cross section knowledge (LA-150h library) and the n+p scattering kinematics.
- The model of response functions was calculated including the realistic geometry arrangement of the Li foil-radiator-detector set. As a simplified approach to the reconstruction procedure, the effects of secondary scattered neutrons were neglected.

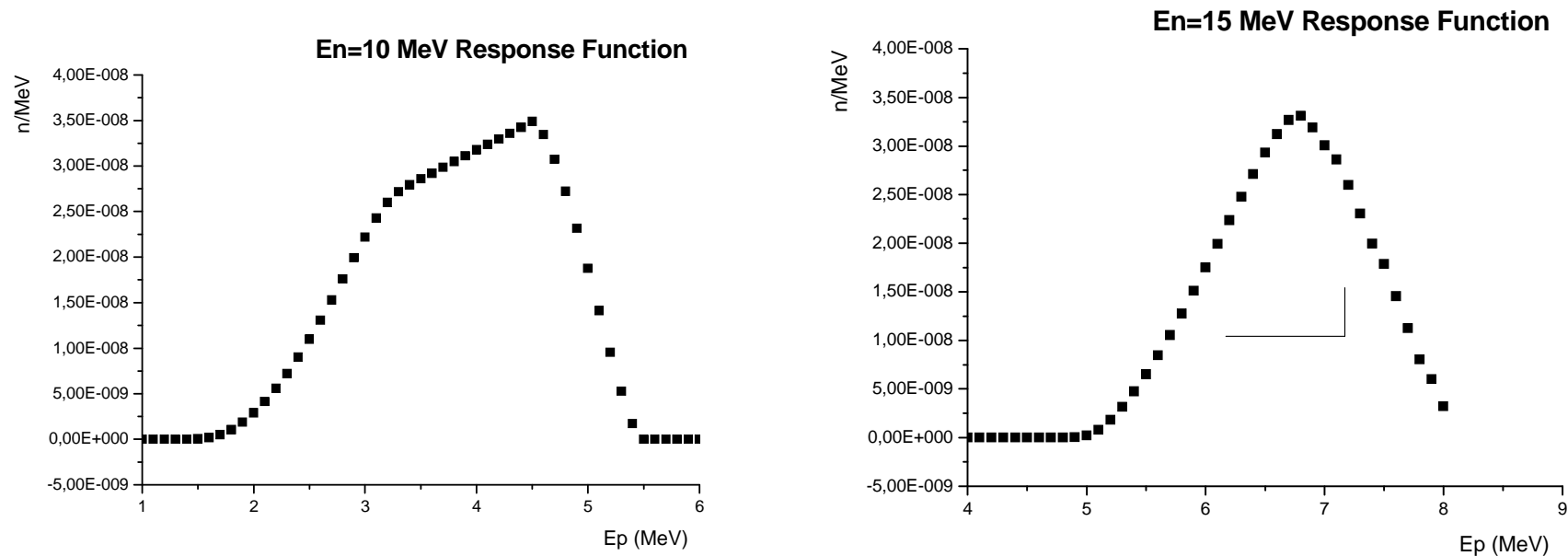

- Response functions were superposed by optimization procedure to fit measured proton-recoil spectrum. Multiplication factors pertaining to response functions create resulting n spectrum.



CH₂ proton-recoil spectrum simulated by MCNPX

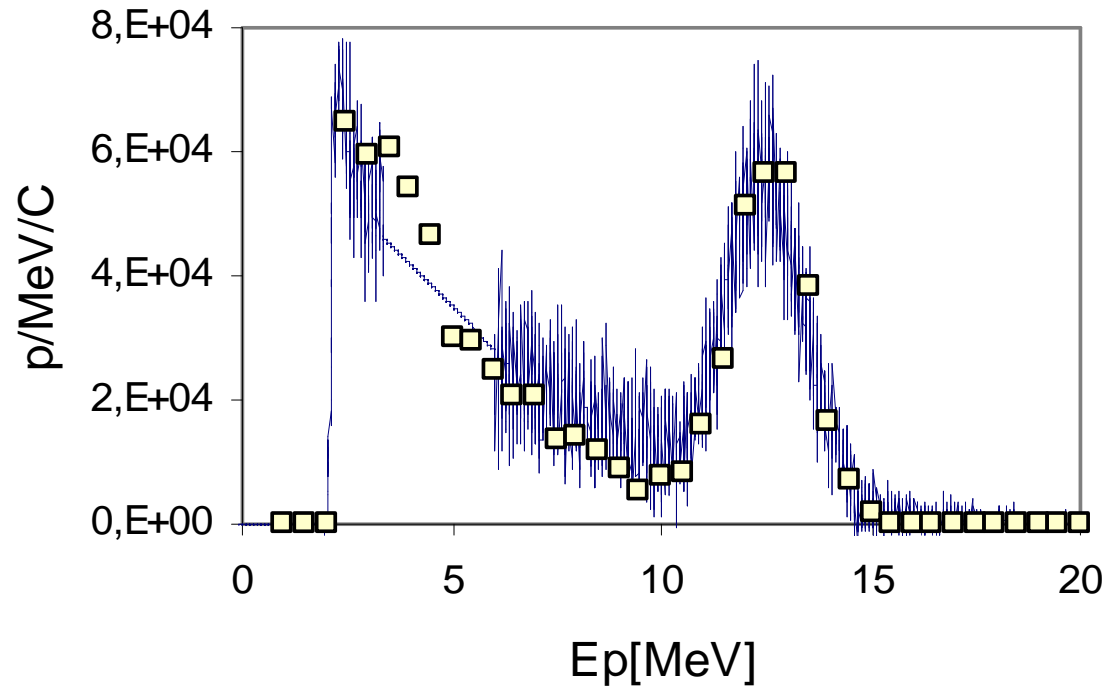

The experimental proton-recoil spectrum (line) is compared with result of MCNPX simulation (squares) for proton energies above 2.5 MeV.

- The MCNPX calculations included all events caused by tracks of neutrons across the radiator and consequent recoil of protons to the solid angle of detector telescope.

•Good overall agreement is indicated:

simulated and experimental mono-energetic peaks are consistent within high statistical accuracy of experiment (0.5%) and the integrated continuum within 6%.

Protons p/C	PRT	MCNP
Total 2,5-15 MeV	3,63E+05	3,48E+05
Peak 10,5-15 MeV	1,37E+05	1,35E+05
Continuum	2,26E+05	2,13E+05



Neutron spectrum

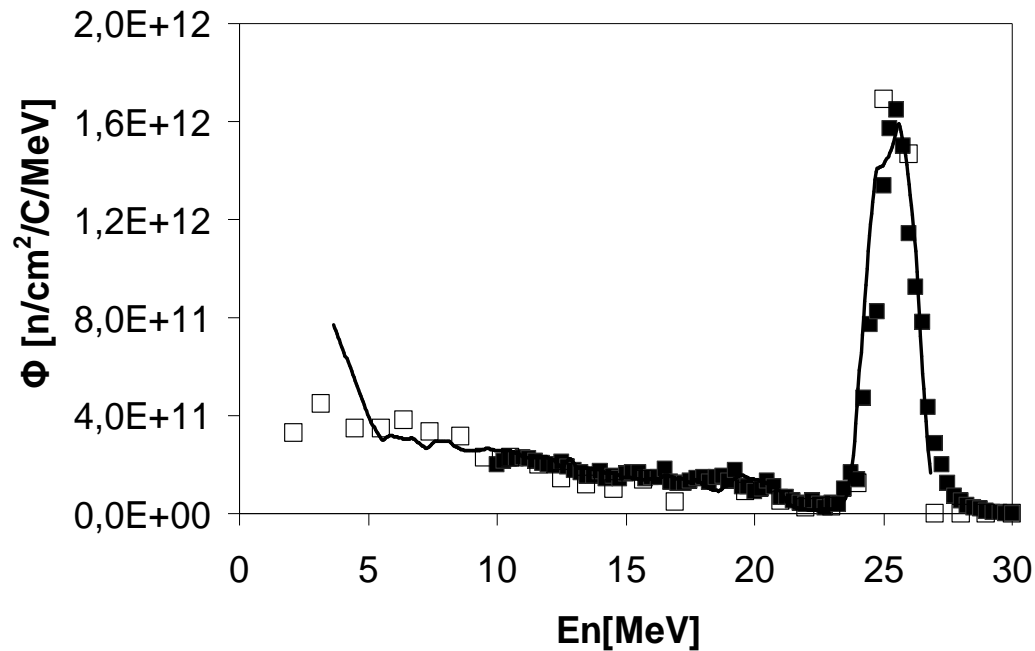

- The MCNPX simulated neutron spectrum calculated for the radiator position (empty squares),
 - the simply extrapolated TOF data of Uwamino (line)
 - and the neutron spectrum deconvoluted from the experimental net-effect proton spectrum (full squares)
- are compared.

✓ The integrated spectra from PRT-data deconvolution agree with MCNPX simulation within 10%.

✓ However, the discrepancy is seen for the continuum. The reason could consist in misinterpretation of parasitic neutrons, which are neglected in the formalism of simplified deconvolution.

	MCNPX prediction	Simplified deconvolution	TOF data extrapolated
	n/cm ² /C		
Total 10-29 MeV	4,60E+12	5,05E+12	5,24E+12
Peak 23-29 MeV	3,31E+12	3,18E+12	3,35E+12
Continuum	1,29E+12	1,87E+12	1,89E+12

✓ The claimed accuracy of the simple extrapolated TOF data (10%) together with possible errors in taking the quantitative data from the figure of the Uwamino report make the comparison less reliable.



Summary

In the investigation of activation cross sections using QME $p\text{-}^7\text{Li}$ source

- *The contribution of low-energy continuum tail of source spectrum to measured reaction rates at energies above cross-section maximum overestimates the contribution of QME peak.*
- *The peak and tail of source spectrum at location of investigated foils is affected by the space-energy integration effects and by transport of neutrons through source assembly.*
- *For the specification of neutron beam at foil positions, spectral flux at sample positions could not be determined by TOF measurement correctly → MCNPX simulation is needed.*
- *Proton-recoil-telescope method was found suitable for validation of MCNPX-simulated neutron flux at foil position. We conclude, that the MCNPX simulation with the MCNPX/LA-150h library well reproduces measured data from proton-recoil-telescope method. Further investigation need to be done to get more reliable interpretation of measured data to explain observed discrepancies between simulated continuum of $p\text{-}^7\text{Li}(C)$ neutron spectrum and data from TOF measurement.*